

KXF 系列
SERIES

基板自立型105℃薄型品
105℃ Low profile, Snap-in Terminal Type

◆ 特 长 / FEATURES

- 105℃、3000小时、高20mm品。
Load Life : 105℃ 3000 hours, with 20mm height.
- RoHS指令对应品。
RoHS compliance.



◆ 规格表 / SPECIFICATIONS

项目 Items	特 性 Characteristics																						
工作温度范围 Category Temperature Range	-40~+105℃	-25~+105℃																					
额定电压范围 Rated Voltage Range	10~100V.DC	160~450V.DC																					
静电容量允许差 Capacitance Tolerance	±20% (20℃, 120Hz)																						
漏 电 流 Leakage Current(MAX)	$I = 3\sqrt{CV}$ (施加额定电压5分钟后) $I = 3\sqrt{CV}$ (After 5 minutes application of rated voltage) I=漏电流 (μA) C=静电容量 (μF) V=额定电压 (V) Leakage Current Capacitance Rated Voltage																						
损失角正切值 (tan δ) Dissipation Factor(MAX)	<table border="1"> <tr> <td>额定电压 (V) Rated Voltage</td> <td>10</td> <td>16</td> <td>25</td> <td>35</td> <td>50</td> <td>63</td> <td>80</td> <td>100</td> <td>160~450</td> <td rowspan="2">(20℃, 120Hz)</td> </tr> <tr> <td>tan δ</td> <td>0.55</td> <td>0.50</td> <td>0.45</td> <td>0.40</td> <td>0.35</td> <td>0.30</td> <td>0.25</td> <td>0.20</td> <td>0.20</td> </tr> </table>		额定电压 (V) Rated Voltage	10	16	25	35	50	63	80	100	160~450	(20℃, 120Hz)	tan δ	0.55	0.50	0.45	0.40	0.35	0.30	0.25	0.20	0.20
额定电压 (V) Rated Voltage	10	16	25	35	50	63	80	100	160~450	(20℃, 120Hz)													
tan δ	0.55	0.50	0.45	0.40	0.35	0.30	0.25	0.20	0.20														
耐 久 性 Endurance	在105℃环境中，不超过额定电压的范围内叠加额定纹波电流，连续加载3000小时后，满足以下各项要求。 After applying rated voltage with rated ripple current for 3000 hours at 105℃, the capacitors shall meet the following requirements.																						
低 温 特 性 Low Temperature Stability (阻抗比) Impedance Ratio (MAX)	静电容量变化率 Capacitance Change	初期值的±20%以内 Within ±20% of the initial value.																					
	损失角正切值 Dissipation Factor	规格值的200%以下 Not more than 200% of the specified value.																					
	漏 电 流 Leakage Current	规格值以下 Not more than the specified value.																					
低 温 特 性 Low Temperature Stability (阻抗比) Impedance Ratio (MAX)	额定电压 (V) Rated Voltage	10~100 160~250 315~450	(120Hz)																				
	Z(-25℃)/Z(20℃)	3 3 8																					
	Z(-40℃)/Z(20℃)	12 - -																					

◆ 纹波电流修正系数 / MULTIPLIER FOR RIPPLE CURRENT

频率系数 Frequency Coefficient

频率 (Hz) Frequency	60(50)	120	500	1k	10k≤
10~100VV	0.90	1.00	1.05	1.10	1.15
160~250VV	0.80	1.00	1.20	1.30	1.50
315~450VV	0.80	1.00	1.20	1.25	1.40

◆ 副记号 / OPTION

副记号 Code	记号 Code
PET套管, 无底板 PET Sleeve without plate	EFC

◆ 产品型号体系 / PART NUMBER

□□□	KXF	□□□□□	M	□□□	SN	D×L
额定电压 Rated Voltage	系列名称 Series	静电容量 Capacitance	静电容量允许差 Capacitance Tolerance	副记号 Option	端子记号 Terminal Code	铝壳尺寸 Case Size

◆ 尺寸图 / DIMENSIONS

(mm)

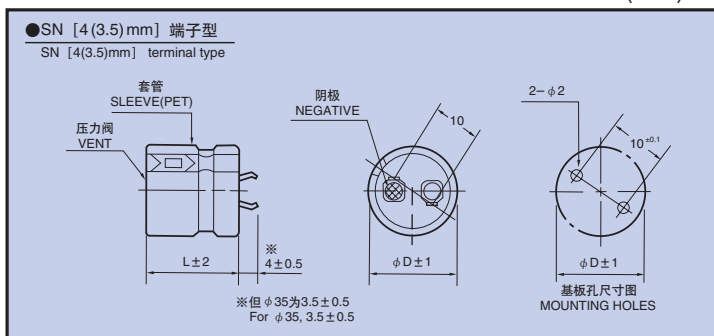



大型铝电解电容器

LARGE CAN TYPE ALUMINUM ELECTROLYTIC CAPACITORS

KXF

◆标准品一览表/STANDARD SIZE

Cap(μF) \ WV	10	16	25	35	50	63	80	100
330								20×20 0.60
390								20×20 0.71
470							20×20 0.65	22×20 0.78
560							20×20 0.70	25×20 0.95
680						20×20 0.83	22×20 0.84	25×20 1.09
820						22×20 0.99	25×20 1.04	30×20 1.32
1000					20×20 0.87	22×20 1.10	25×20 1.19	
1200					22×20 1.02	25×20 1.20	30×20 1.44	
1500				20×20 0.80	25×20 1.15	30×20 1.47		
1800				22×20 0.94	25×20 1.34	30×20 1.52		
2200			20×20 0.98	22×20 1.04	30×20 1.60			
2700			22×20 1.08	25×20 1.29				
3300		20×20 1.06	22×20 1.29	30×20 1.45				
3900		20×20 1.25	25×20 1.58					
4700	20×20 0.98	22×20 1.38	25×20 1.61					
5600	20×20 1.16	25×20 1.68						
6800	22×20 1.31	25×20 1.80						
8200	25×20 1.59							
10000	25×20 1.77							

Cap(μF) \ WV	160	180	200	220	250	315	350	385
39								20×20 0.35
47							20×20 0.38	20×20 0.38
56						20×20 0.41	20×20 0.40	22×20 0.42
68						22×20 0.48	22×20 0.45	25×20 0.50
82						22×20 0.51	25×20 0.54	25×20 0.52
100						25×20 0.57	25×20 0.57	30×20 0.61
120					20×20 0.65	30×20 0.65	30×20 0.65	30×20 0.64
150				20×20 0.70	22×20 0.74	30×20 0.70	35×20 0.78	35×20 0.80
180		20×20 0.80	20×20 0.80	22×20 0.80	22×20 0.77	35×20 0.85	35×20 0.85	
220	20×20 0.81	22×20 0.90	22×20 0.87	25×20 0.85	25×20 0.95	35×20 0.90		
270	22×20 0.98	22×20 0.95	25×20 0.95	25×20 1.02	30×20 1.00			
330	25×20 1.02	25×20 1.15	25×20 1.15	30×20 1.12	30×20 1.16			
390	25×20 1.25	25×20 1.20	30×20 1.20	30×20 1.25	35×20 1.25			
470	30×20 1.30	30×20 1.36	30×20 1.41	35×20 1.45				
560	30×20 1.46	30×20 1.43	35×20 1.43					
680	35×20 1.51	35×20 1.51						
820	35×20 1.55							

Cap(μF) \ WV	400	420	450
39			20×20 0.36
47	20×20 0.39	20×20 0.38	20×20 0.41
56	20×20 0.40	22×20 0.45	22×20 0.43
68	22×20 0.49	22×20 0.48	25×20 0.50
82	25×20 0.55	25×20 0.53	25×20 0.53
100	25×20 0.60	30×20 0.58	30×20 0.61
120	30×20 0.75	30×20 0.70	30×20 0.70
150	30×20 0.80	35×20 0.80	35×20 0.80
180	35×20 0.85		

↑ 纹波电流 Ripple Current (A r.m.s./120Hz, 105°C)
铝壳尺寸 Case Size φD×L(mm)