

YXF 系列
SERIES

105°C长寿命低阻抗品
105°C Long Life. Low impedance.

◆特 长 / FEATURES

- 105°C、4000~10000小时品。
Load Life : 105°C 4000~10000 hours.
- 高频率阻抗规格设定。
Prescribe Impedance value at 100 kHz.
- RoHS指令对应品
RoHS compliance.

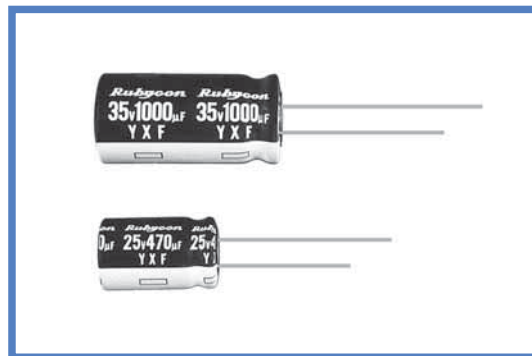

◆规格表 / SPECIFICATIONS

项 目 Items	特 性 Characteristics																														
工作温度范围 Category Temperature Range	-40~+105°C																														
额定电压范围 Rated Voltage Range	6.3~100V.DC																														
静电容量允许差 Capacitance Tolerance	±20% (20°C, 120Hz)																														
漏 电 流 Leakage Current(MAX)	小于 $I=0.01CV$ 和 $3\mu A$ 中的较大值 (施加额定电压2分钟后) $I=0.01CV$ or $3\mu A$ whichever is greater. (After 2 minutes) I=漏电流 (µA) Leakage Current C=静电容量 (µF) Capacitance V=额定电压 (V) Rated Voltage																														
损失角正切值 (tan δ) Dissipation Factor(MAX)	<table border="1"> <tr> <td>额定电压 (V) Rated Voltage</td> <td>6.3</td> <td>10</td> <td>16</td> <td>25</td> <td>35</td> <td>50</td> <td>63</td> <td>100</td> <td>(20°C, 120Hz)</td> </tr> <tr> <td>tan δ</td> <td>0.22</td> <td>0.19</td> <td>0.16</td> <td>0.14</td> <td>0.12</td> <td>0.10</td> <td>0.09</td> <td>0.08</td> <td></td> </tr> </table> <p>对于静电容量超过1000µF的产品, 其静电容量每增加1000µF, 则损失角正切值在上表值的基础上加上0.02。 When capacitance is over 1000µF, tan δ shall be added 0.02 to the listed value with increase of every 1000µF.</p>	额定电压 (V) Rated Voltage	6.3	10	16	25	35	50	63	100	(20°C, 120Hz)	tan δ	0.22	0.19	0.16	0.14	0.12	0.10	0.09	0.08											
额定电压 (V) Rated Voltage	6.3	10	16	25	35	50	63	100	(20°C, 120Hz)																						
tan δ	0.22	0.19	0.16	0.14	0.12	0.10	0.09	0.08																							
耐 久 性 Endurance	<p>在105°C环境中, 不超过额定电压的范围内叠加额定纹波电流, 连续加载右表时间后, 满足以下各项要求。 After life test with rated ripple current at conditions stated in the table below at 105°C, the capacitors shall meet the following requirements.</p> <table border="1"> <tr> <td rowspan="2">静电容量变化率 Capacitance Change</td> <td>初期值的±25%以内 Within ±25% of the initial value.</td> <td rowspan="2">铝壳尺寸 Case Size</td> <td colspan="2">时间(hrs) Life Time</td> </tr> <tr> <td>损失角正切值 Dissipation Factor</td> <td>规格值的200%以下 Not more than 200% of the specified value.</td> <td>6.3~10WV</td> <td>16~100WV</td> </tr> <tr> <td>漏 电 流 Leakage Current</td> <td>规格值以下 Not more than the specified value.</td> <td>φ D ≤ 6.3</td> <td>4000</td> <td>5000</td> </tr> <tr> <td></td> <td></td> <td>φ D = 8, 10</td> <td>6000</td> <td>7000</td> </tr> <tr> <td></td> <td></td> <td>φ D = 12.5</td> <td>8000</td> <td>10000</td> </tr> </table>	静电容量变化率 Capacitance Change	初期值的±25%以内 Within ±25% of the initial value.	铝壳尺寸 Case Size	时间(hrs) Life Time		损失角正切值 Dissipation Factor	规格值的200%以下 Not more than 200% of the specified value.	6.3~10WV	16~100WV	漏 电 流 Leakage Current	规格值以下 Not more than the specified value.	φ D ≤ 6.3	4000	5000			φ D = 8, 10	6000	7000			φ D = 12.5	8000	10000						
静电容量变化率 Capacitance Change	初期值的±25%以内 Within ±25% of the initial value.		铝壳尺寸 Case Size		时间(hrs) Life Time																										
	损失角正切值 Dissipation Factor	规格值的200%以下 Not more than 200% of the specified value.		6.3~10WV	16~100WV																										
漏 电 流 Leakage Current	规格值以下 Not more than the specified value.	φ D ≤ 6.3	4000	5000																											
		φ D = 8, 10	6000	7000																											
		φ D = 12.5	8000	10000																											
低 温 特 性 Low Temperature Stability (阻抗比) Impedance Ratio(MAX)	<table border="1"> <tr> <td>额定电压 (V) Rated Voltage</td> <td>6.3</td> <td>10</td> <td>16</td> <td>25</td> <td>35</td> <td>50</td> <td>63</td> <td>100</td> <td>(120Hz)</td> </tr> <tr> <td>Z(-25°C)/Z(20°C)</td> <td>4</td> <td>3</td> <td>2</td> <td>2</td> <td>2</td> <td>2</td> <td>2</td> <td>2</td> <td></td> </tr> <tr> <td>Z(-40°C)/Z(20°C)</td> <td>8</td> <td>6</td> <td>4</td> <td>3</td> <td>3</td> <td>3</td> <td>3</td> <td>3</td> <td></td> </tr> </table>	额定电压 (V) Rated Voltage	6.3	10	16	25	35	50	63	100	(120Hz)	Z(-25°C)/Z(20°C)	4	3	2	2	2	2	2	2		Z(-40°C)/Z(20°C)	8	6	4	3	3	3	3	3	
额定电压 (V) Rated Voltage	6.3	10	16	25	35	50	63	100	(120Hz)																						
Z(-25°C)/Z(20°C)	4	3	2	2	2	2	2	2																							
Z(-40°C)/Z(20°C)	8	6	4	3	3	3	3	3																							

◆纹波电流修正系数 / MULTIPLIER FOR RIPPLE CURRENT
频率系数 Frequency Coefficient

频率 (Hz) Frequency	120	1k	10k	100k≤
1~10µF	0.42	0.60	0.80	1.00
22~33µF	0.55	0.75	0.90	1.00
47~330µF	0.70	0.85	0.95	1.00
470~1000µF	0.75	0.90	0.98	1.00
2200~15000µF	0.80	0.95	1.00	1.00

◆副记号 / OPTION

记号 Code
PET套管 PET Sleeve EFC

◆尺寸图 / DIMENSIONS (mm)

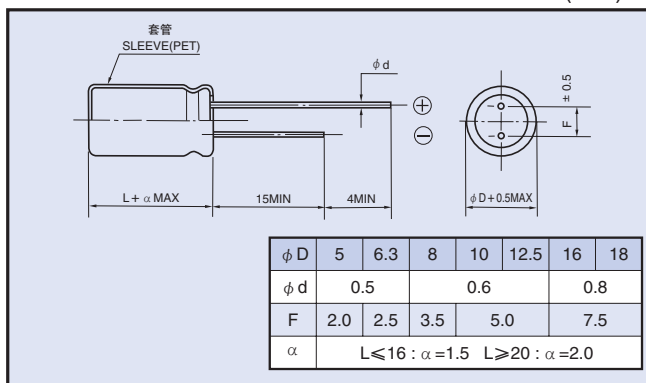

◆产品型号体系 / PART NUMBER

□□□ 额定电压 Rated Voltage	YXF 系列名称 Series	□□□□□ 静电容量 Capacitance	M 静电容量允许差 Capacitance Tolerance	□□□ 副记号 Option	□□ 引线加工记号 Lead Forming	D × L 铝壳尺寸 Case Size
------------------------------	-----------------------	------------------------------	---------------------------------------	----------------------	------------------------------	----------------------------

◆标准品一览表 / STANDARD SIZE

额定电压 Rated Voltage (V · DC)	静电容量 capacitance (μF)	外形尺寸 Size φ D×L(mm)	额定纹波电流 Rated ripple current (mA r.m.s./105°C, 100kHz)	阻抗 (Ω MAX) Impedance	
				20°C, 100kHz	-10°C, 100kHz
6.3 (0J)	100	5×11	150	0.90	3.6
	220	6.3×11	250	0.40	1.6
	330	6.3×11	250	0.40	1.6
	470	8×11.5	400	0.25	1.0
	1000	10×12.5	580	0.16	0.65
	2200	12.5×20	1300	0.062	0.21
	3300	12.5×20	1300	0.062	0.21
	4700	16×25	1850	0.034	0.096
	6800	16×25	1850	0.034	0.096
	10000	16×31.5	2000	0.029	0.087
15000	18×35.5	2200	0.025	0.058	
10 (1A)	100	5×11	150	0.90	3.6
	220	6.3×11	250	0.40	1.6
	330	8×11.5	400	0.25	1.0
	470	8×11.5	400	0.25	1.0
	1000	10×16	770	0.12	0.46
	2200	12.5×20	1300	0.062	0.21
	3300	12.5×25	1650	0.048	0.16
	4700	16×25	1850	0.034	0.096
	6800	16×31.5	2000	0.029	0.087
	10000	18×35.5	2200	0.025	0.058
16 (1C)	47	5×11	150	0.90	3.6
	100	6.3×11	250	0.40	1.6
	220	8×11.5	400	0.25	1.0
	330	8×11.5	400	0.25	1.0
	470	10×12.5	580	0.16	0.65
	1000	10×20	1050	0.078	0.30
	2200	12.5×25	1650	0.048	0.16
	3300	16×25	1850	0.034	0.096
4700	16×31.5	2000	0.029	0.087	
6800	18×35.5	2200	0.025	0.058	
25 (1E)	33	5×11	150	0.90	3.6
	47	5×11	150	0.90	3.6
	100	6.3×11	250	0.40	1.6
	220	8×11.5	400	0.25	1.0
	330	10×12.5	580	0.16	0.65
	470	10×16	770	0.12	0.46
	1000	12.5×20	1300	0.062	0.21
	2200	16×25	1850	0.034	0.096
	3300	16×31.5	2000	0.029	0.087
4700	18×35.5	2200	0.025	0.058	
35 (1V)	33	5×11	150	0.90	3.6
	47	6.3×11	250	0.40	1.6
	100	8×11.5	400	0.25	1.0
	220	10×12.5	580	0.16	0.65
	330	10×16	770	0.12	0.46
	470	10×20	1050	0.078	0.30
	1000	12.5×25	1650	0.048	0.16
	2200	16×31.5	2000	0.029	0.087
3300	18×35.5	2200	0.025	0.058	

额定电压 Rated Voltage (V · DC)	静电容量 capacitance (μF)	外形尺寸 Size φ D×L(mm)	额定纹波电流 Rated ripple current (mA r.m.s./105°C, 100kHz)	阻抗 (Ω MAX) Impedance	
				20°C, 100kHz	-10°C, 100kHz
50 (1H)	1	5×11	30	4.0	8.0
	2.2	5×11	43	2.5	6.0
	3.3	5×11	53	2.2	5.6
	4.7	5×11	88	1.9	5.0
	10	5×11	100	1.5	4.0
	22	5×11	150	0.90	3.6
	33	6.3×11	250	0.40	1.6
	47	6.3×11	250	0.40	1.6
	100	8×11.5	400	0.25	1.0
	220	10×16	770	0.12	0.46
	330	10×20	1050	0.078	0.30
	470	12.5×20	1300	0.062	0.21
	1000	16×25	1850	0.034	0.096
	2200	18×35.5	2200	0.025	0.058
63 (1J)	10	5×11	87	2.3	9.3
	22	6.3×11	140	1.3	5.2
	33	6.3×11	140	1.2	5.0
	47	8×11.5	210	0.63	2.8
	100	10×12.5	300	0.43	1.8
	220	10×20	520	0.21	0.84
	330	12.5×20	660	0.16	0.64
	470	12.5×25	750	0.12	0.45
	1000	16×31.5	1390	0.054	0.20
	100 (2A)	1	5×11	20	4.5
2.2		5×11	30	3.0	13.0
3.3		5×11	40	2.7	11.0
4.7		5×11	65	2.5	10.0
10		6.3×11	140	1.2	5.0
22		8×11.5	160	0.63	2.8
33		10×12.5	230	0.43	1.8
47		10×16	290	0.31	1.5
100		12.5×20	430	0.16	0.64
220		16×25	900	0.073	0.27
330		16×25	900	0.073	0.27