



FEATURES

- **Miniature Size** - 3.3 mm x 6.9 mm
- **Simple Interface** - No signal conditioning required
- **Made in USA** - fully automated production, 100% testing, worldwide quality and price leader
- **Fast Response** - < 100 μ S
- **Multiple Sensitivities** - 10 G to 1400 G standard
- **Nano-power** - As little as 50 nA
- **Industrial Rated** - 10 year life, -40° C to 85° C

FUNCTIONAL DIAGRAM

FUNCTION

- On / off shock & acceleration sensing

APPLICATIONS

- Motion triggered wake-up
- GPS tracking, RFID, vehicle electronics
- Security, anti-tamper, anti-theft, alarms

DESCRIPTION

The SQ-ASx series act like acceleration sensitive switches that opens or closes when accelerated past an acceleration threshold.

The sensor can be used to produce CMOS or TTL pulses to interrupt (wake up) a microcontroller. Alternatively, these pulses can be counted to estimate the amount and duration of activity. The sensor is fully passive, requires no signal conditioning, and operates with zero current or only 50 nA depending on model.

PATENTS

Patented. US 7326866, 7067748, 7326867, 7421793. Patents pending.

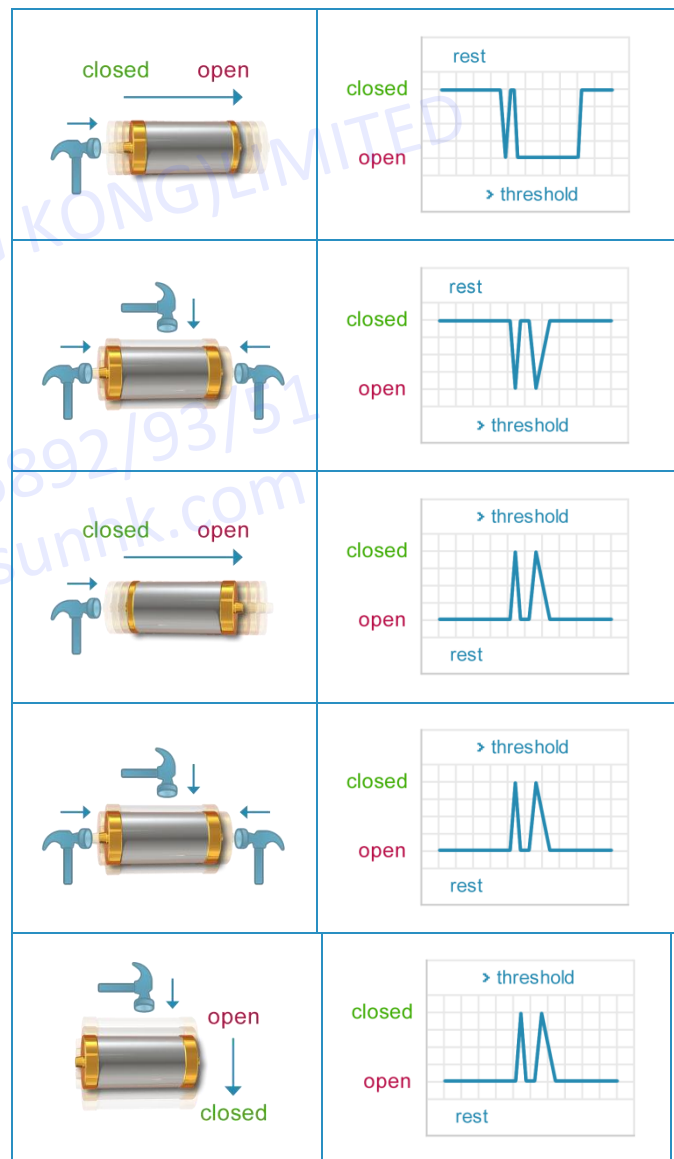

* See Theory of Operation for more details.

TABLE OF CONTENTS

Electrical Characteristics 3
 Dimensions 3-4
 Example PCB Landing 5
 Theory of Operation 6
 Part Comparison 7
 Production Grades 7
 Packaging Options 7
 Example Complete Part Number 7
 Limitations and Warnings 8
 Testing 8
 System Integration Testing 8
 Notice 8
 Further Information 8
 Notes 8

RIVERSUN(HONG KONG)LIMITED

+86-755-26055892/93/51
 service@riversunhk.com

ELECTRICAL CHARACTERISTICS

PARAMETER	MIN	MAX
Supply Voltage Range	0.5 V	12 V
Current Sink*	50 nA (0.05 μ A)	10 mA

* Current consumption is determined by the resistance of the application circuit and the supply voltage.

DIMENSIONS FOR ASA, ASC, & ASE

PHYSICAL SIZE

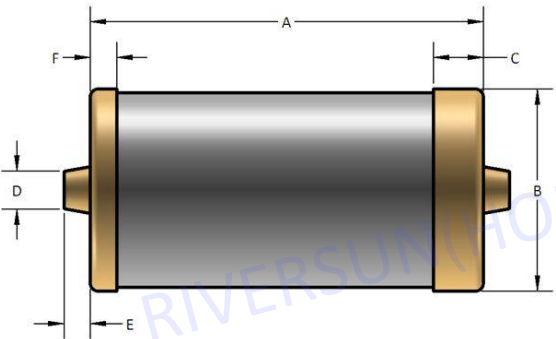

SYMBOL	DESCRIPTION	MM	TOLERANCE
A	Length	6.8	± 0.25
B	Diameter	3.3	± 0.1
C	Terminal Width	0.8	± 0.25
D	Solder Nub Diameter	0.9	± 0.25
E	Solder Nub Length	0.4	± 0.1
F	Terminal Width 2	.4	± 0.25

DIMENSIONS ASB & ASD

PHYSICAL SIZE

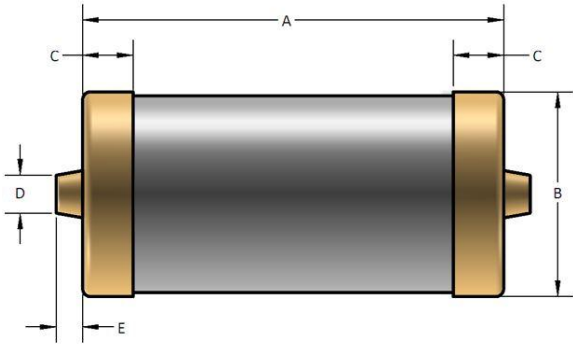

SYMBOL	DESCRIPTION	MM	TOLERANCE
A	Length	6.8	±0.25
B	Diameter	3.3	±0.1
C	Terminal Width	0.8	±0.25
D	Solder Nub Diameter	0.9	±0.25
E	Solder Nub Length	0.4	±0.1



RIVERSUN(HONG KONG)LIMITED
+86-755-26055892/93/51
service@riversunhk.com

EXAMPLE PCB LANDING

RECOMMENDED PCB LANDING			ALTERNATE, PCB CUTOUT LANDING (USE FOR LOWEST PROFILE)		
SYMBOL	DESCRIPTION	MM	SYMBOL	DESCRIPTION	MM
A	Pitch	6.0	A	Recess Length	7.25
B	Pad Length	1.2	B	Pad Length	0.8
C	Pad Width	2.1	C	Pad Width	1.5
			D	Recess Width	3.6

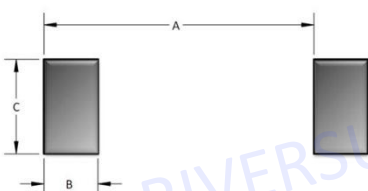

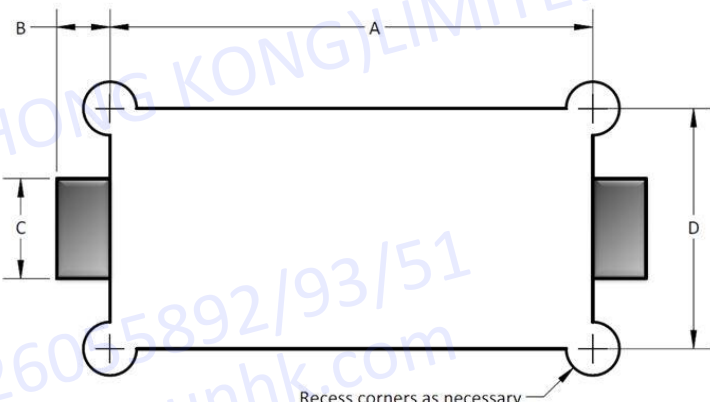

***Note:** Alternative layouts may be used to optimize size or manufacturability

THEORY OF OPERATION

SQ-ASA

The SQ-ASA series sensor is a normally **closed** device. It is designed to be sensitive only in one direction. However, it will exhibit some off axis sensitivity. Typical cross axis open signals are in the 2 – 8 mS range, where on axis open signals are proportional to the duration of acceleration above the threshold.

SQ-ASB

The SQ-ASB series sensor is a normally **closed** device. It is designed to be sensitive in all directions. It is about 4 times more sensitive off axis than on axis. Typical cross axis open signals are in the 2 – 8 mS range, where on axis open signals are proportional to the duration of acceleration above the threshold. **NOTE:** If better accuracy is required, choose the cross axis specification that matches your requirements and use two sensors at 90 degrees to one another, logically “OR’ed” together.

SQ-ASC

The SQ-ASC series sensor is a normally **open** device. It is designed to be sensitive only in one direction and is very immune to cross axis acceleration. Only if a cross axis event is 10 times greater than the rated threshold may the sensor trigger in a cross axis mode.

SQ-ASD

The SQ-ASD series sensor is a normally **open** device. It is designed to be sensitive in all directions. The sensor will trigger radially or in the terminal 1→2 direction when acceleration is applied. In the terminal 2→1 direction, the sensor will trigger after the acceleration is removed (rebound effect). **NOTE:** If using the rebound trigger in the 2→1 direction is not appropriate for the application, mount two sensor parallel in opposite directions.

SQ-ASE

The SQ-ASE series sensor is a normally **open** device. It is designed to be sensitive in a radial direction. The sensor will trigger radially when acceleration is applied. **NOTE:** To achieve an omnidirectional response mount two sensors at 90 degrees to one another, logically “OR’ed” together.

PART COMPARISON

PART NUMBER	TYPE	SENSITIVITY	ACCELERATION THRESHOLD (ON AXIS)	CROSS AXIS SENSITIVITY
SQ-ASA-150	Normally closed	One axis, single sided	150 G	Crackle at 75 G, less than < 10 mS pulse width
SQ-ASB-010	Normally closed	Omnidirectional	5 - 20 G	2 - 5 G
SQ-ASE-060	Normally open	Radial axis	60 -1400 G	

PRODUCT COMPARISON

GRADE	ASSEMBLY METHOD	SEALING	WASH TOLERANCE	PB-FREE, ROHS	OPERATING TEMPERATURE
C	Reflow Solder: 260° C peak Hand Assembly: 315° C peak, 2 -3 seconds on end terminal	Yes	Washable	Yes	-25°C to + 70°C
I	Reflow Solder: 260° C peak Hand Assembly: 315° C peak, 2 -3 seconds on end terminal	Yes	Washable	Yes	-40°C to + 85°C

ORDERING GUIDE

PART NUMBER	PACKAGING CODE	COMPLETE ORDER NUMBER
SQ-ASx-xxx-C	TR - Tape on Reel	SQ-ASA-150-CTR
SQ-ASx-xxx-I	CT - Cut Tape TR - Tape on Reel	SQ-ASB-010-ICT SQ-ASE-060-ITR

LIMITATIONS AND WARNINGS

This product is not designed for use in life support and/or safety equipment where malfunction of the product can reasonably be expected to result in personal injury or death. Buyer uses this product in such applications at Buyer's own risk and agrees to defend, indemnify, and hold harmless SignalQuest, Inc. from any and all damages, claims, suits, or expenses resulting from such misuse.

TESTING

The performance of each sensor is verified through build-time testing.

SYSTEM INTEGRATION TESTING

Thorough testing should be carried out prior to product release to ensure system integration has not introduced unforeseen problems. The system integrator assumes the ultimate responsibility for the safety of the target application.

NOTICE

Information furnished by SignalQuest, Inc is believed to be accurate and reliable. However, this document may contain ERRORS and OMMISIONS. Accordingly, the design engineer should use this document as a reference rather than a strict design guideline and should perform thorough testing of any product that incorporates this or any other SignalQuest product. No responsibility is assumed by SignalQuest, Inc. for this use of this information, nor for any infringements of patents or other rights of third parties that may result from its use. Specifications are subject to change without notice. No license is granted by implication or otherwise under any patent or patent rights of SignalQuest, Inc. Trademarks and registered trademarks are the property of their respective companies.

FURTHER INFORMATION

For pricing, deliveries, and ordering information, please contact SignalQuest at (603) 448-6266
For updates on this and other documents, visit our website at www.signalquest.com.

NOTES