

DTS□W-2 SERIES

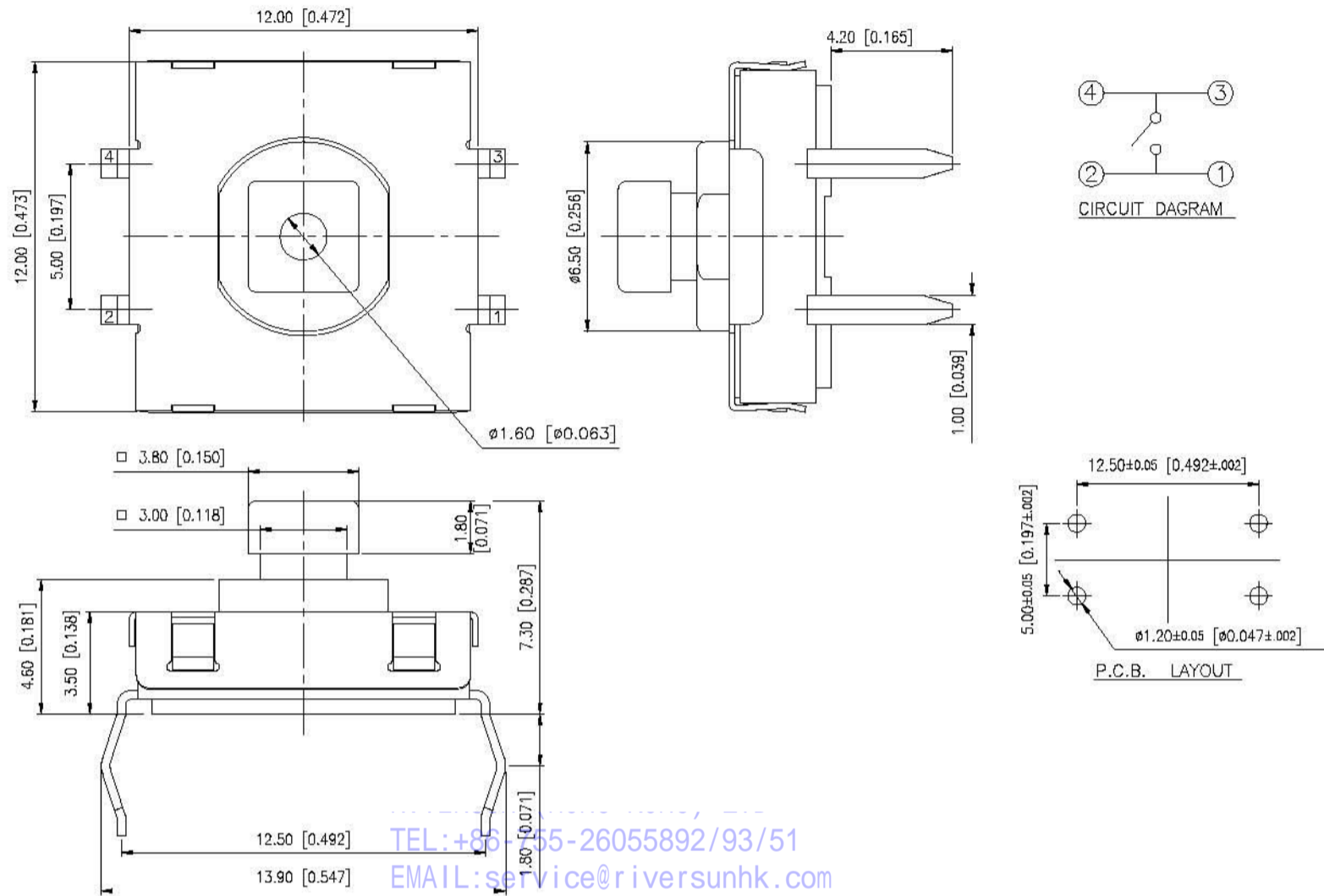

DIMENSIONS

DTSHW-24□-Q



General Tolerance : $\pm 0.2\text{mm}$

TEL: +86-55-26055892/93/51
 EMAIL: service@riversunhk.com
 WEB: www.riversunhk.com

DTSMW-24□-Q

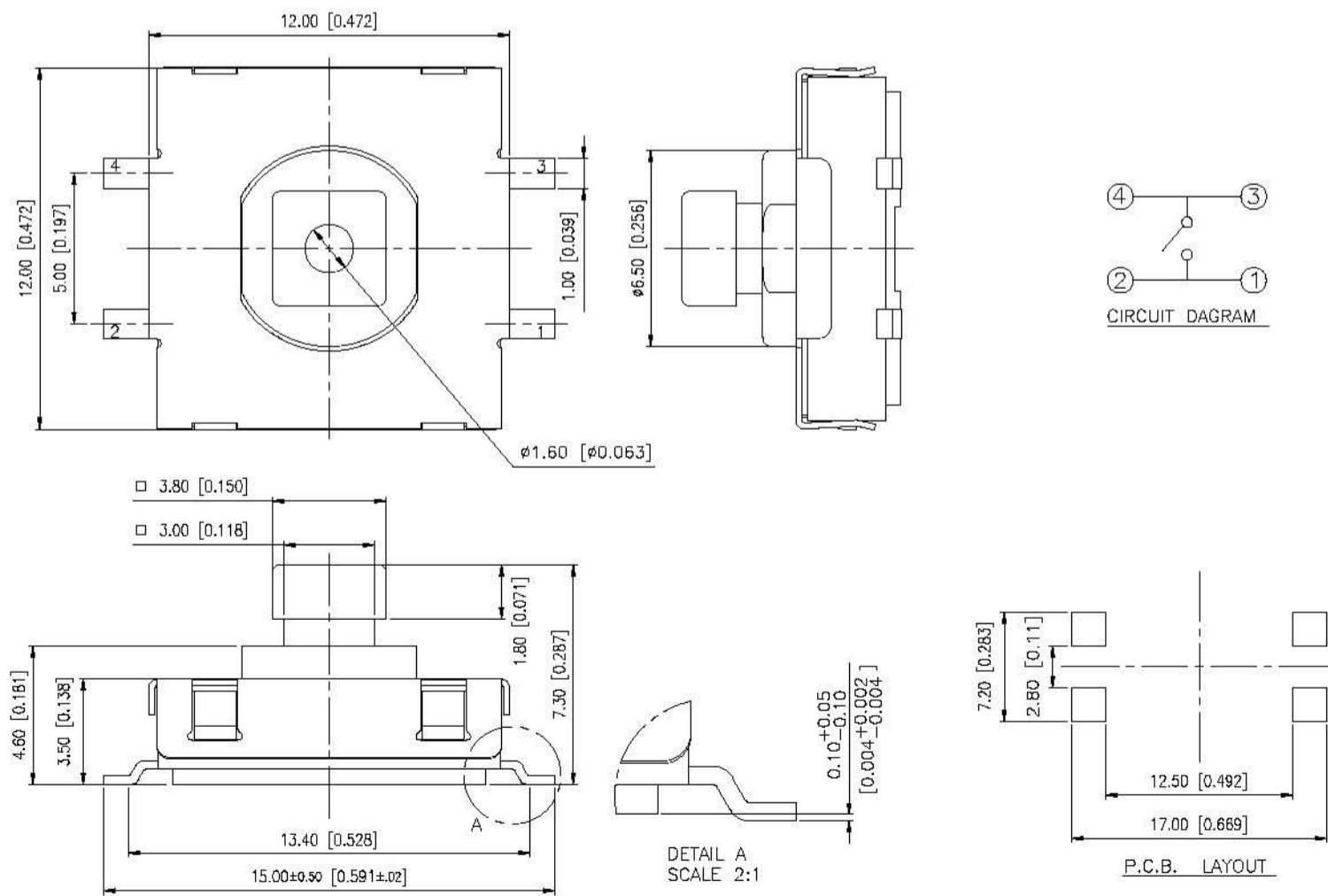

General Tolerance : $\pm 0.2\text{mm}$

DTSMW-21□-Q

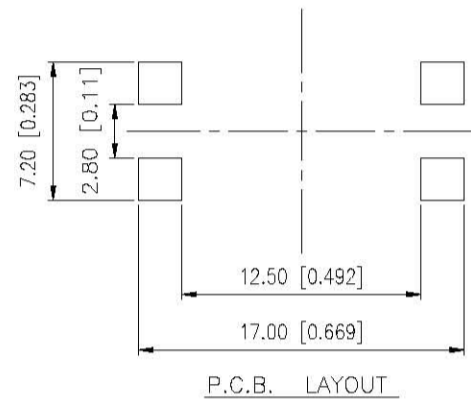
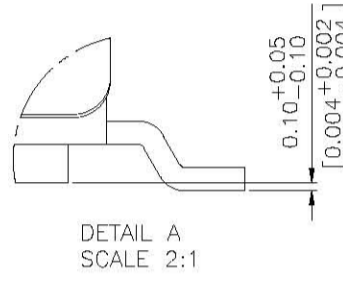
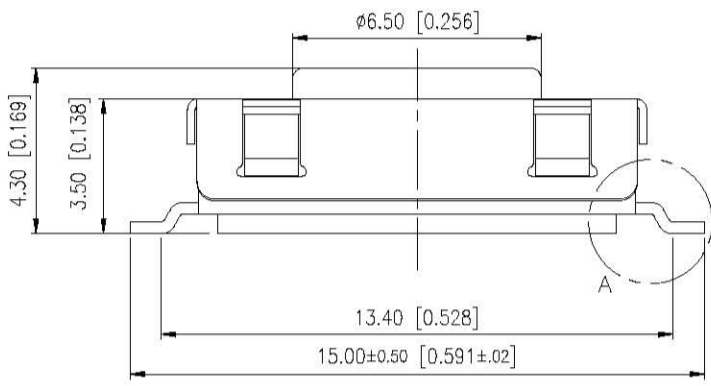
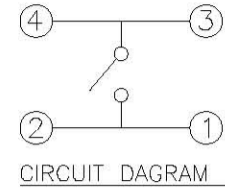
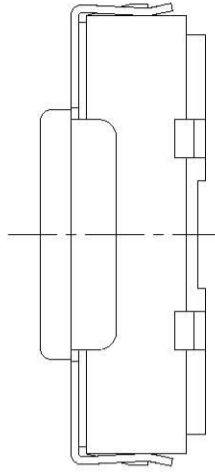
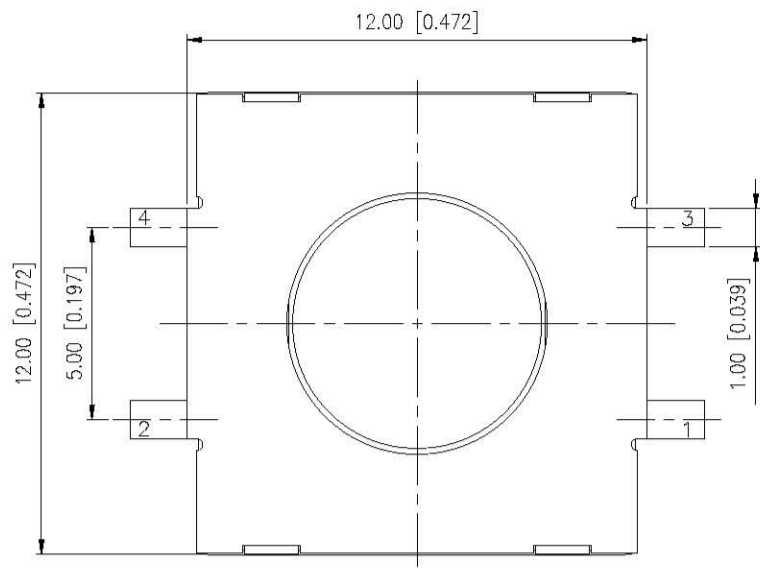

General Tolerance : $\pm 0.2\text{mm}$

TEL: +86-755-26055892/93/51
 EMAIL: service@riversunhk.com
 WEB: www.riversunhk.com

DTSHW-21□-Q

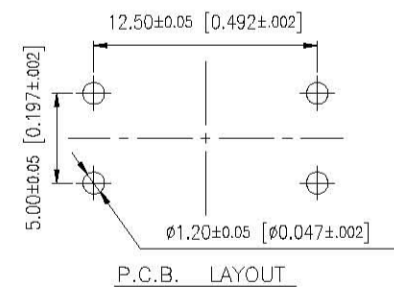
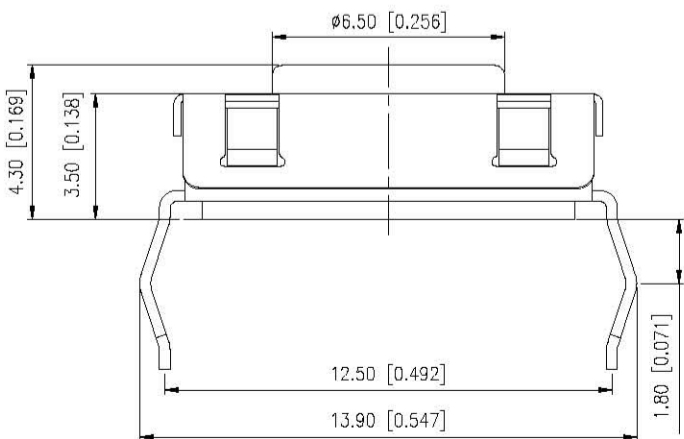
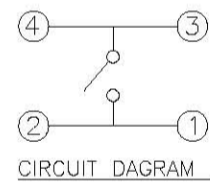
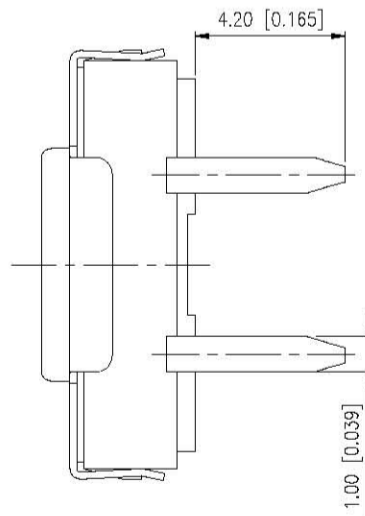
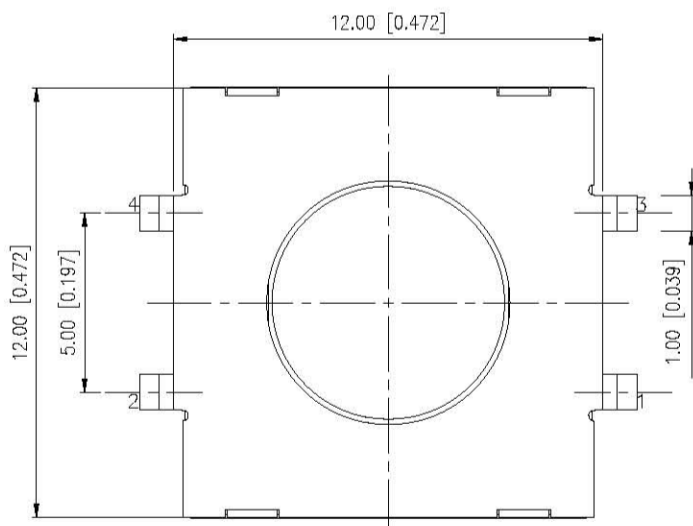

General Tolerance : $\pm 0.2\text{mm}$

HOW TO ORDER

D T S W - 2 - Q -

Package:
B=Tube
T/R=Tape & Reel (Only for SMT)

Halogen Free

Color Of Stem For Operating Force:

K=Black,100gf
N=Brown,160gf
R=Red,260gf
S=White,320gf
Y=Yellow,520gf

Height:

1=4.3mm
4=7.3mm

With Washable Tape

Termination Type :

M = SMT
H = Through Hole

SPECIFICATION

△MECHANICAL

Operation Force:

520± 130gf, Yellow (Y)
320± 80gf, Salmon (S)
260± 50gf, Red (R)
160± 50gf, Brown (N)
100± 50gf, Black (B)

Stroke: 0.35±0.10mm

Operation Temperature: -40°C to +80°C

Storage Temperature Range : -40°C+85°C

△ELECTRICAL

Electrical Life:

1,000,000 cycles min. for 100gf, 160gf, 260gf
500,000 cycles min. for 320gf, 520gf

Rating: 50mA, 24VDC

Contact Resistance: 100mΩ max.

Insulation Resistance: 100MΩ min. at 250VDC

Dielectric Strength: 250VAC/ minute

Contact Arrangement: 1 pole 1 throw

MATERIAL

△COVER: Stainless steel

△TERMINAL: Brass with silver plated

△BASE: UL94V-0 High-Temp. Thermoplastic
Color: Black

△CONTACT : STAINLESS STEEL

△STEM : UL94V-0 High-Temp. Thermoplastic

△Sealed Gasket : Silicone
Color: Black

SOLDERING PROCESS

△WAVE SOLDERING : Recommended solder temperature at 500°F (260°C) max. 5 seconds subject to PCB 1.6mm thickness (soldering for through hole type)

△HAND SOLDERING : Use a soldering iron of 30 watts, controlled at 350°C approximately 5 seconds while applying solder.

△REFLOW SOLDERING :

△ Temperature Profile:

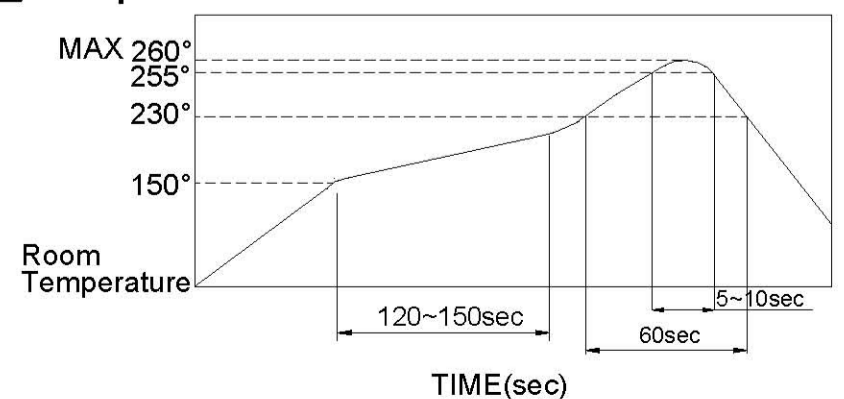

PACKING

Part Number	Number Per Tube	Number Per Reel
DTS□W-21-Q	39	700
DTS□W-24-Q	39	450

PACKING

DTS□W-2 REEL

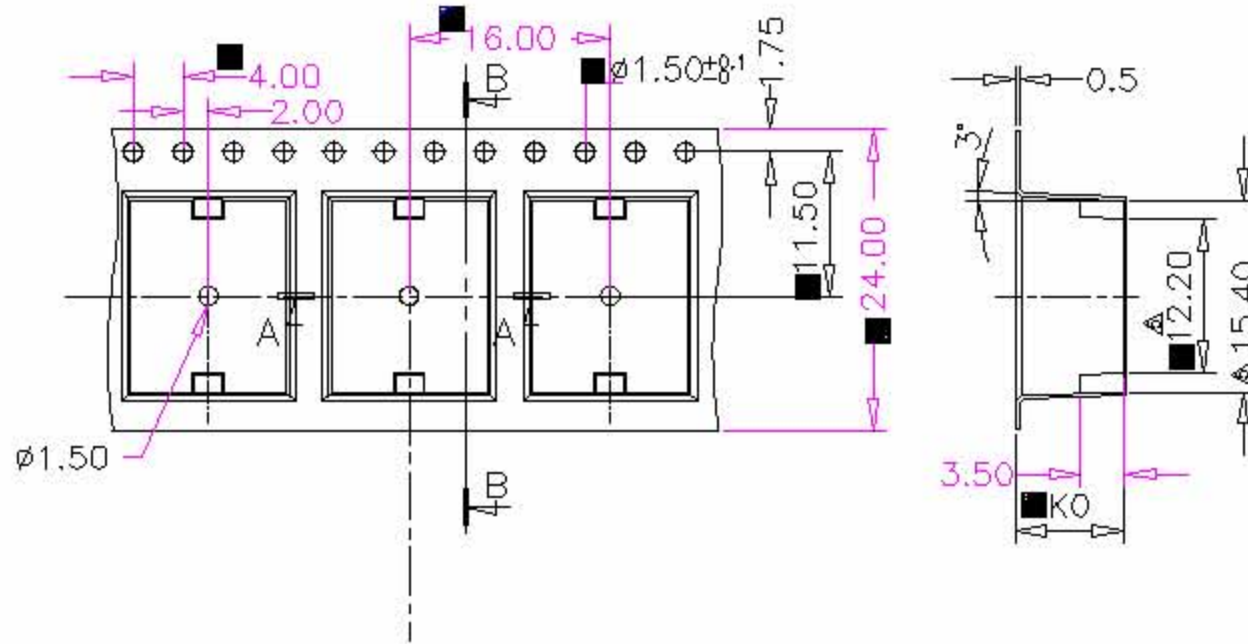

GENERAL TOLERANCES MAX: ± 0.1 mm.

DTS□W-2 TUBE

TEL: +86-755-26055892/93/51
 EMAIL: service@riversunhk.com
 WEB: www.riversunhk.com

