

ML6 SERIES

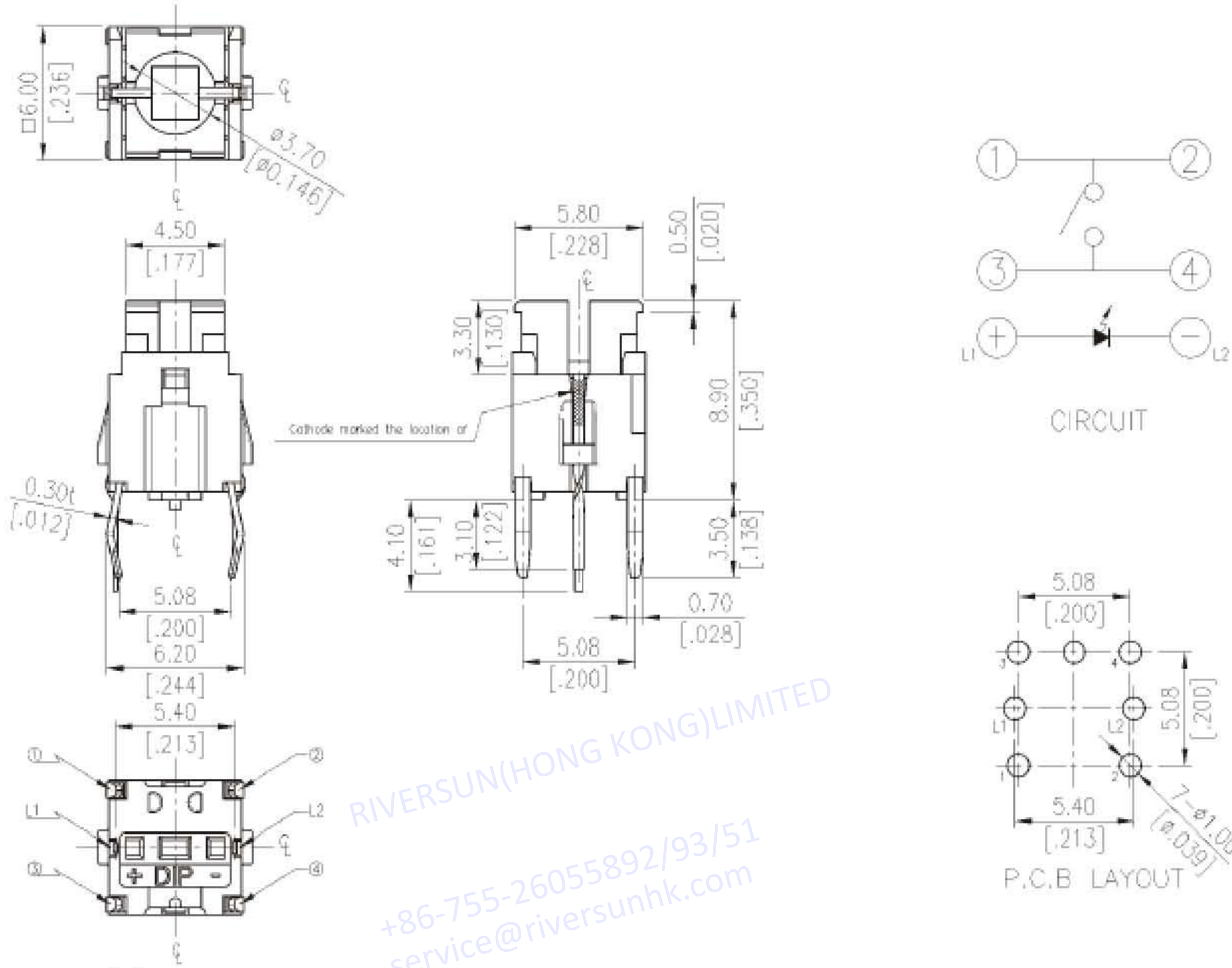

DIMENSION

ML6-H0



General Tolerance : $\pm 0.2\text{mm}$

ML6-H1

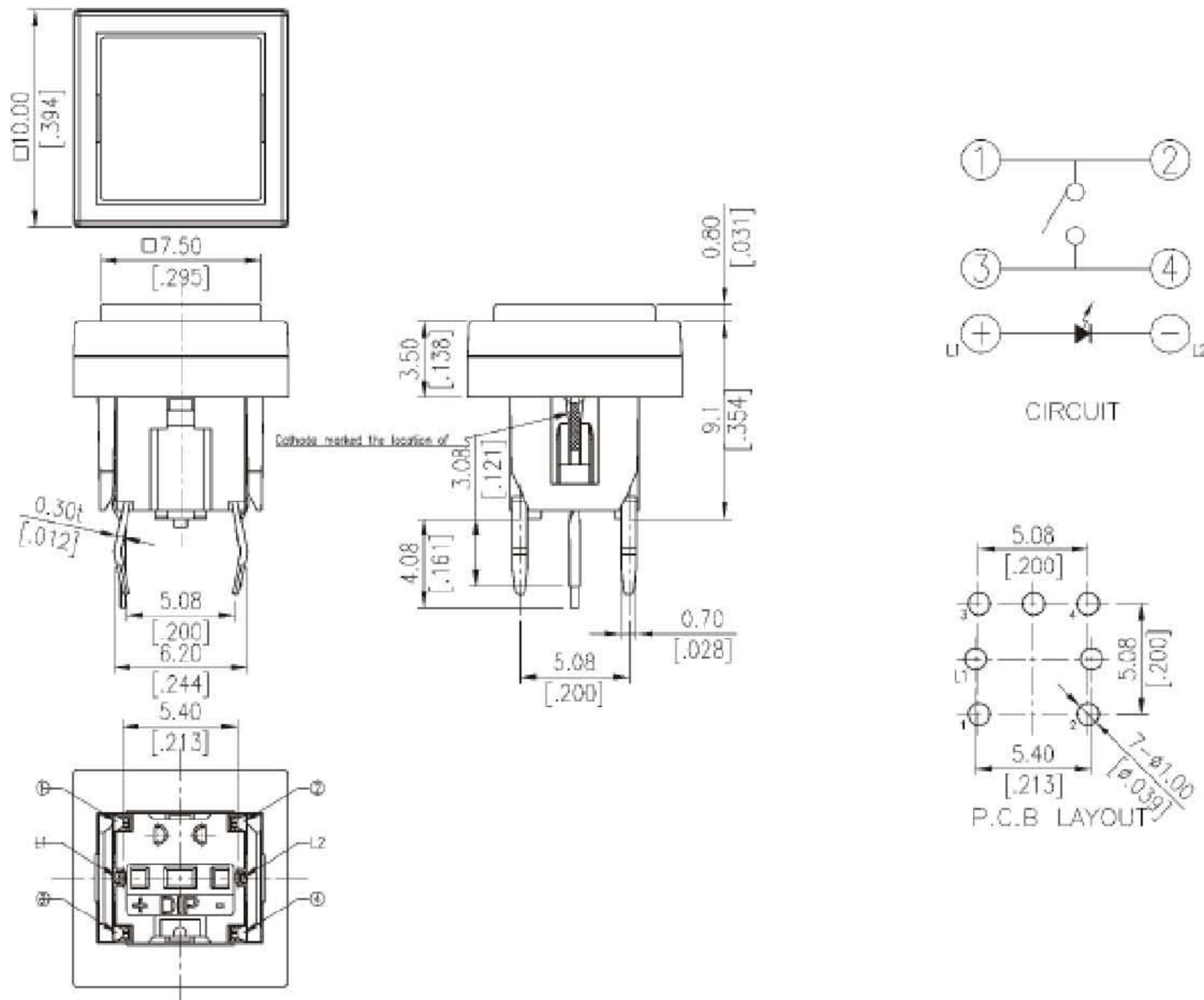

General Tolerance : $\pm 0.2\text{mm}$

RIVERSUN(HONG KONG)LIMITED
 +86-755-26055892/93/51
 service@riversunhk.com

ML6-H2

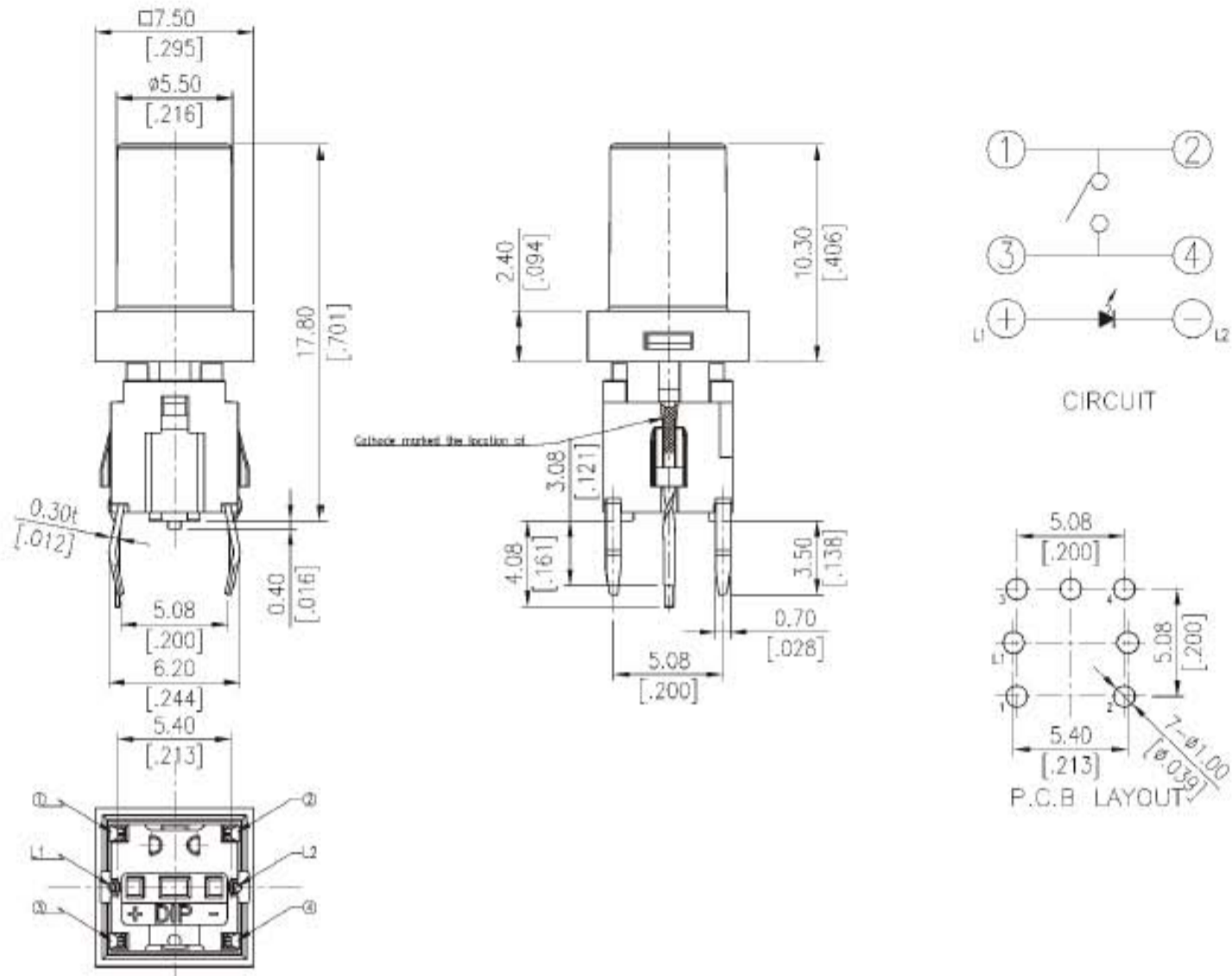

General Tolerance : $\pm 0.2\text{mm}$

ML6-H4

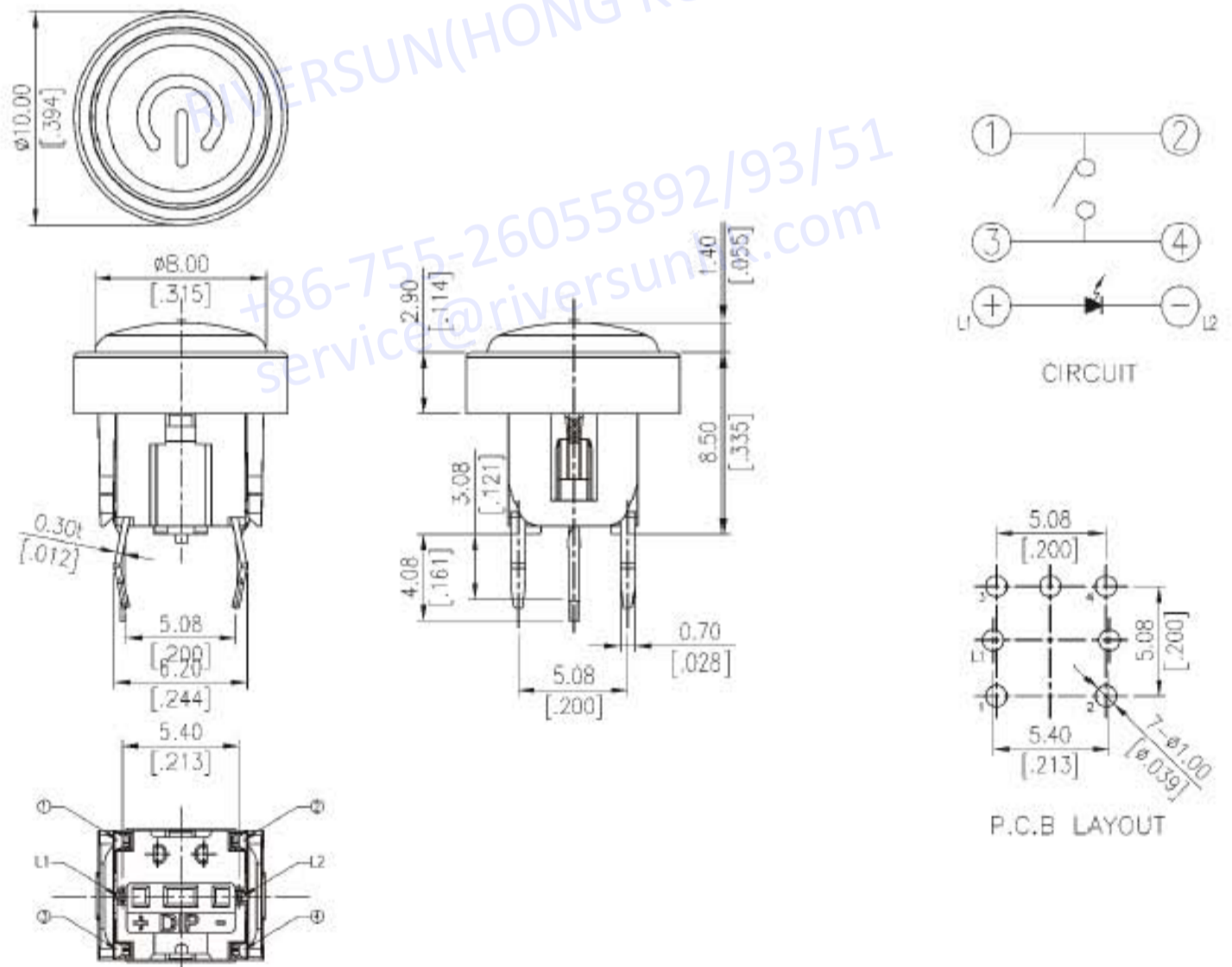

General Tolerance : $\pm 0.2\text{mm}$

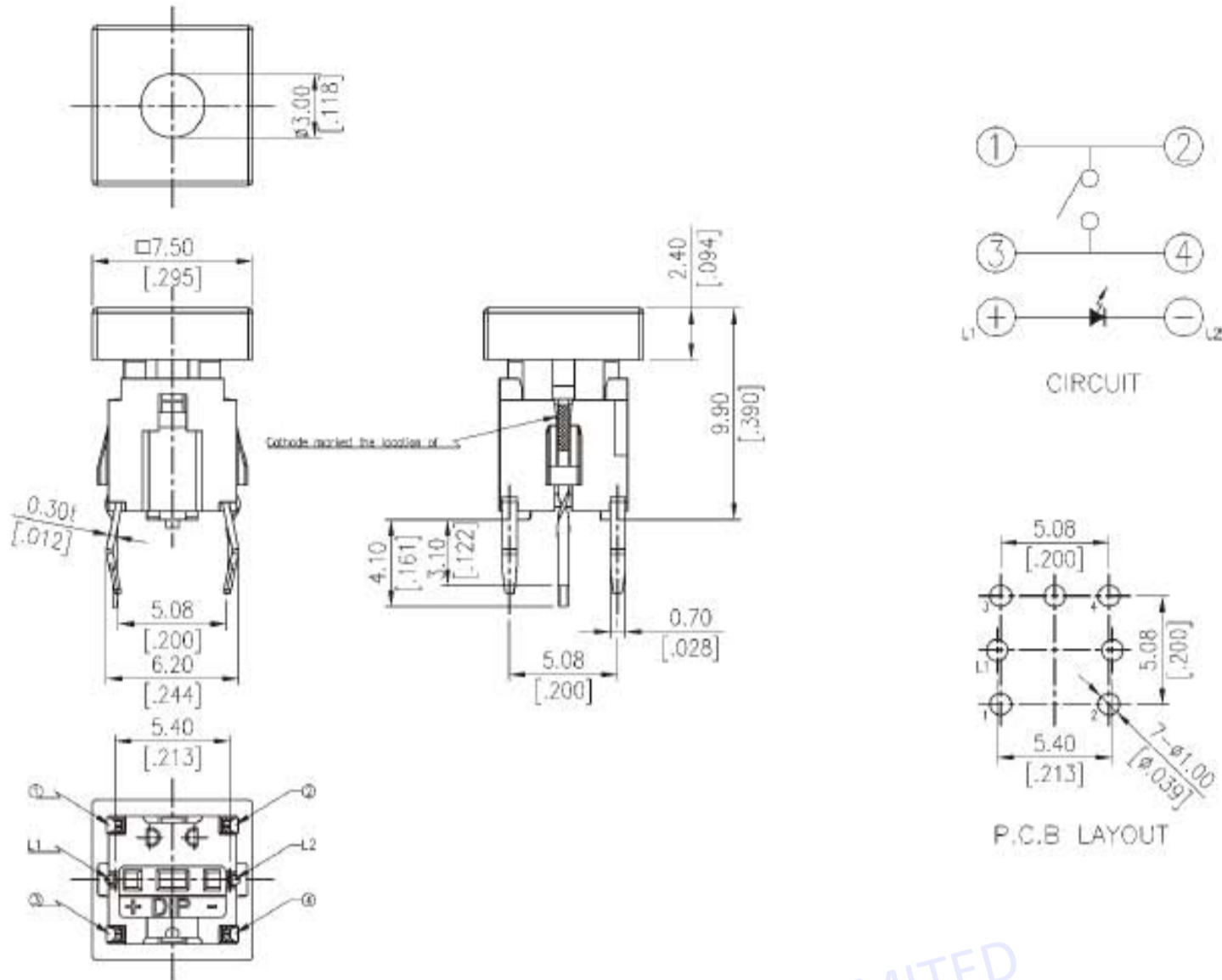

General Tolerance : $\pm 0.2\text{mm}$

HOW TO ORDER ML6-H0

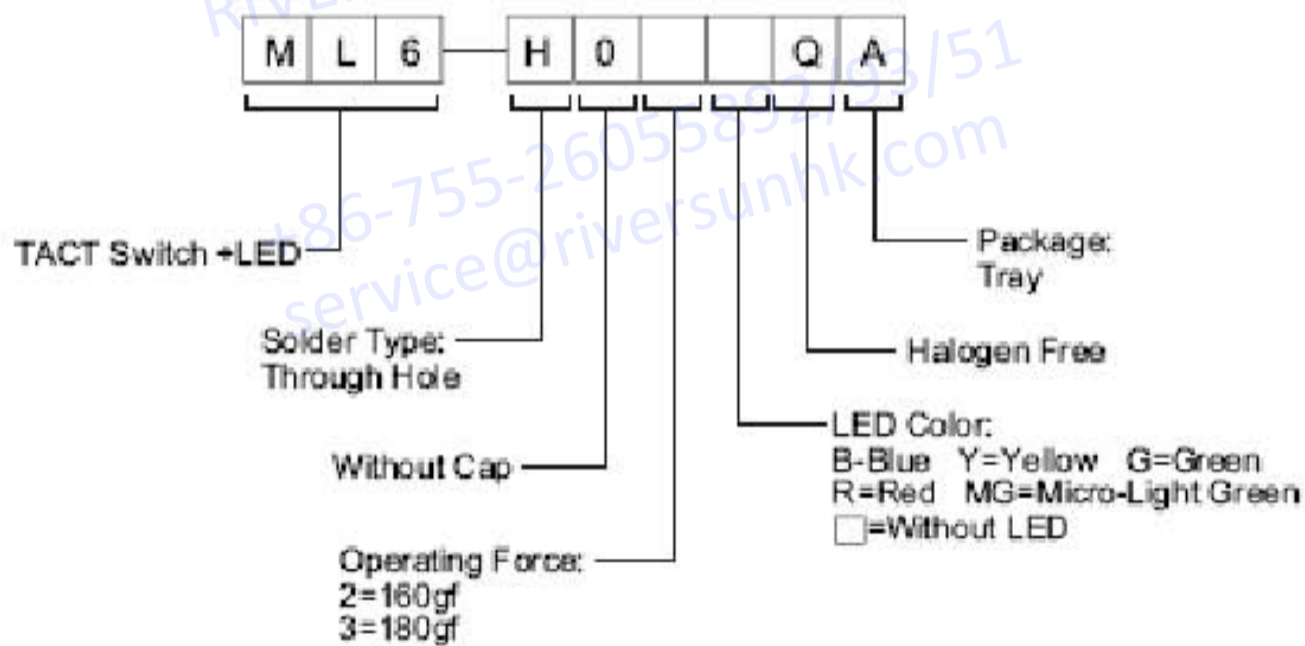

ML6-H1

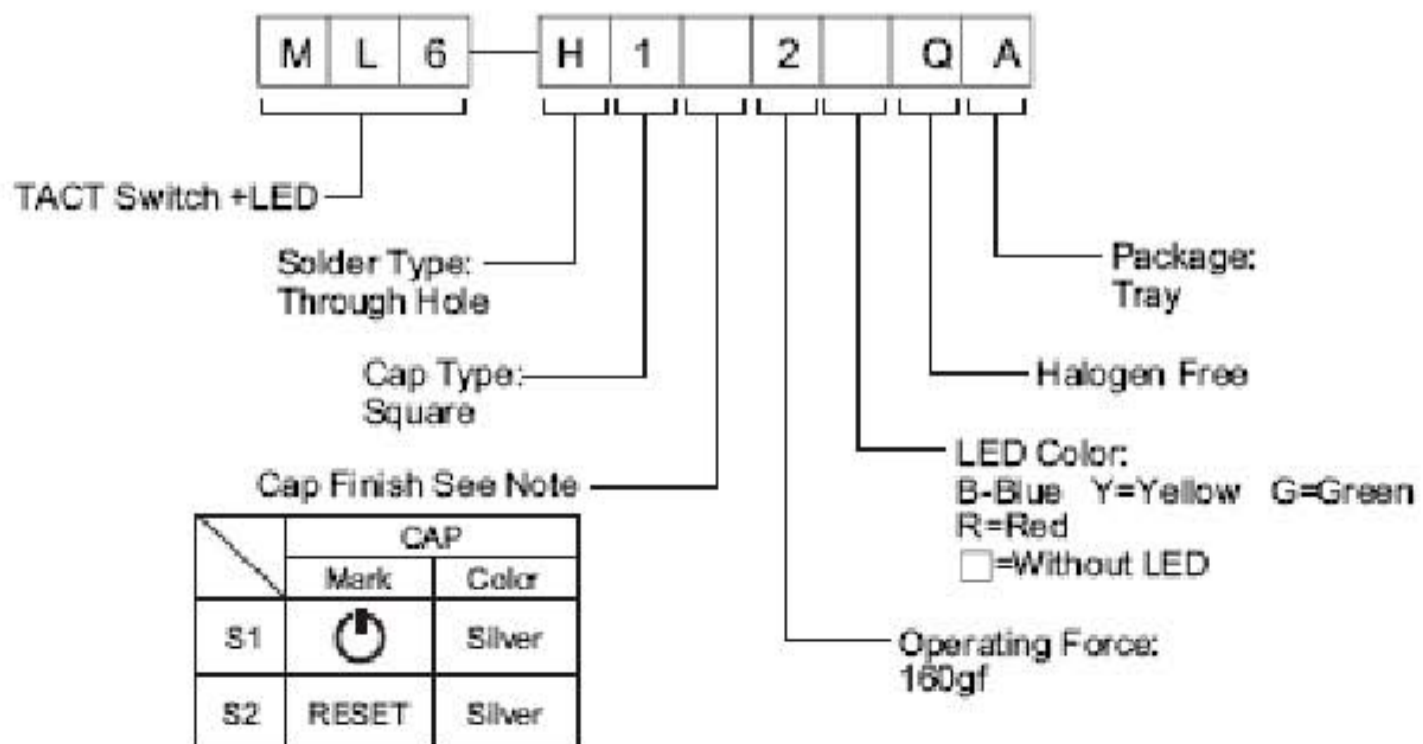

ML6-H2

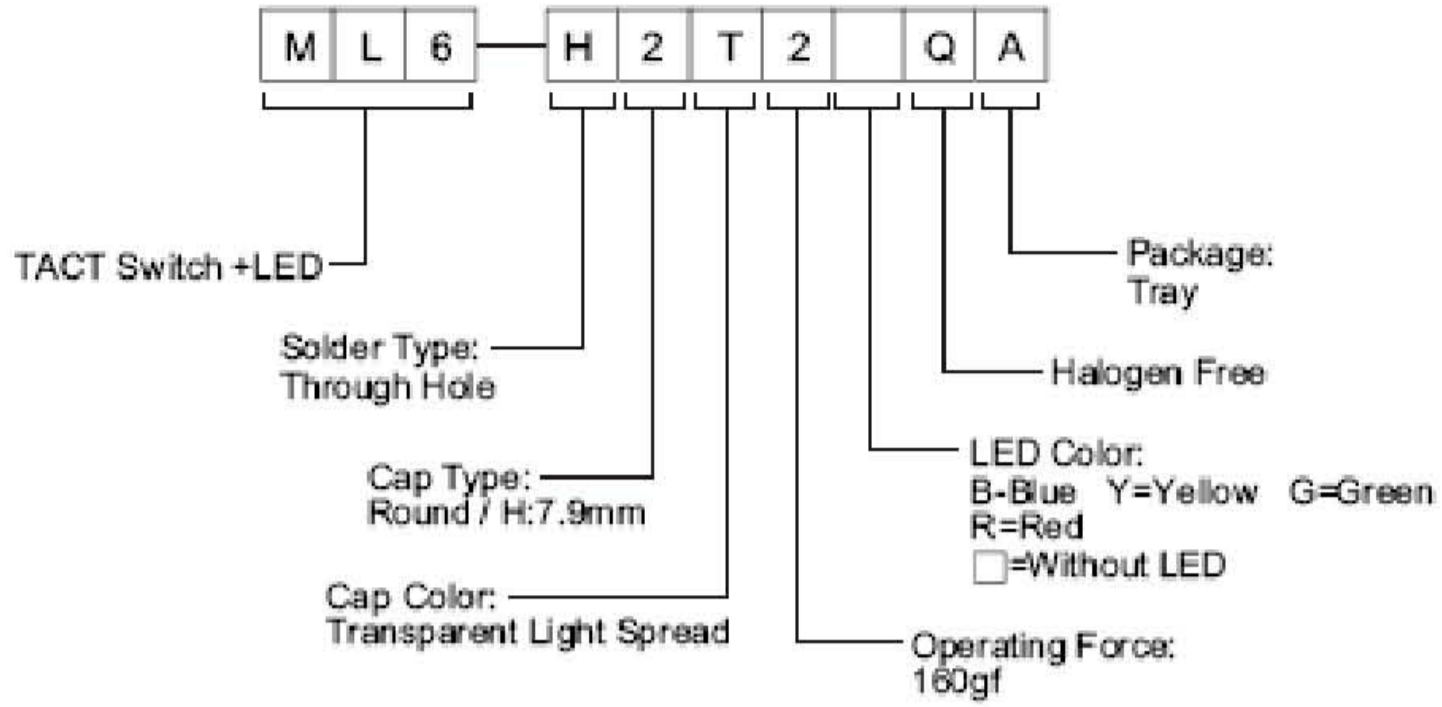

ML6-H4

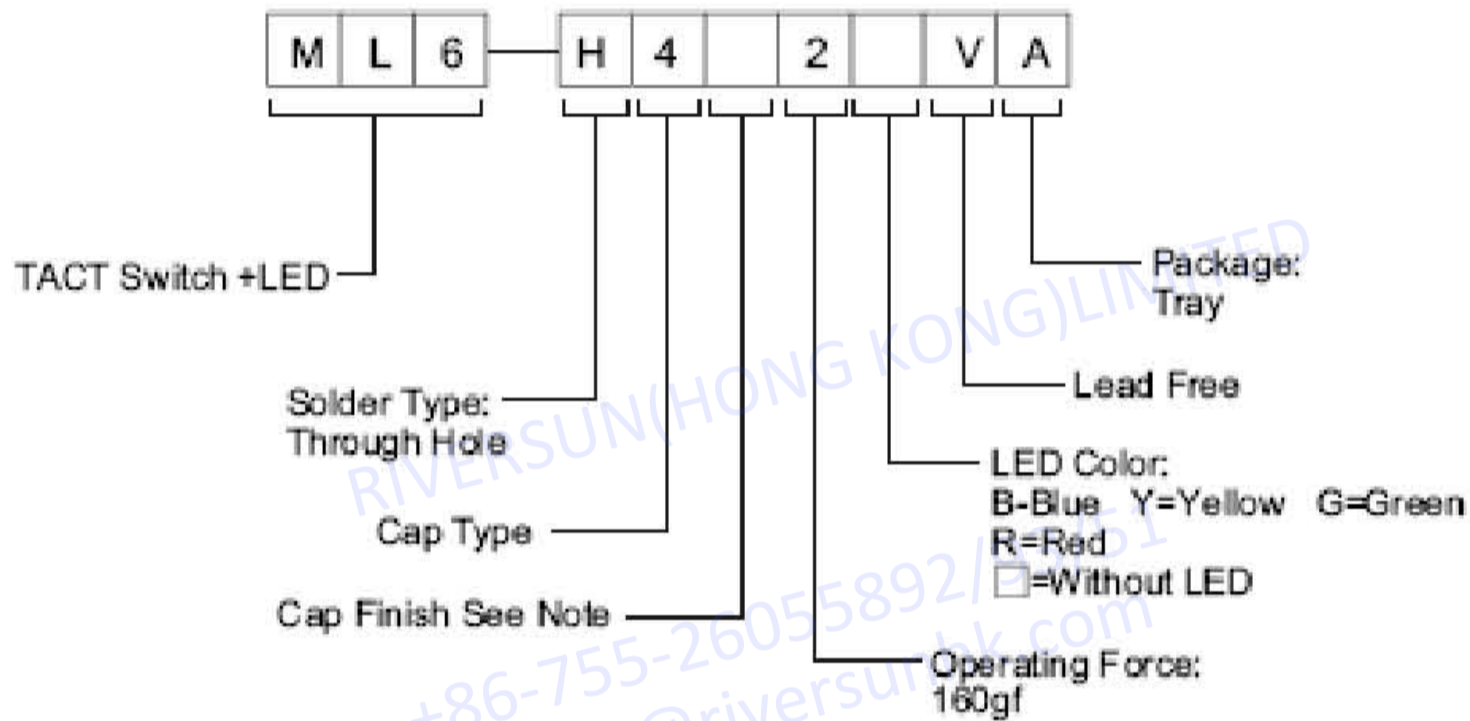

| | CAP | |
|----|-------|--------|
| | Mark | Color |
| K1 | ⏻ | Black |
| S1 | | Silver |
| K3 | RESET | Black |
| S3 | | Silver |

ML6-H6

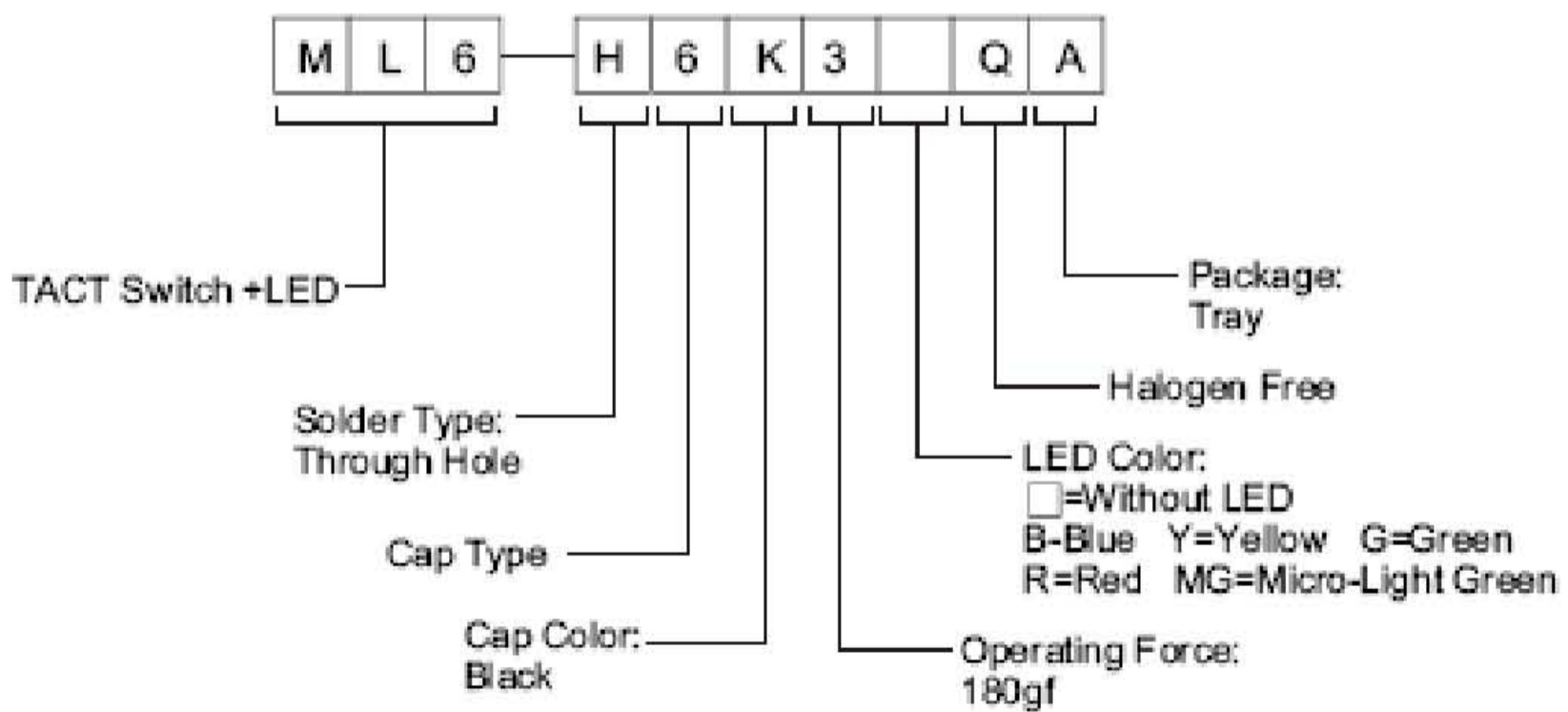

SPECIFICATION

△MECHANICAL

Operation Force : 160±50gf . 180±50gf

Stroke : 0.25±0.15mm

Operation Temperature Range : -40°C to +85°C

Preservative Temperature Range Single condition : -40°C to +85°C

△ELECTRICAL

Electrical Life : 300,000 cycles

50 mA, 12 VDC

Contact Resistance : 100 mΩ max.

Insulation Resistance : 100MΩ min. at 100 VDC

Dielectric Strength: 250 VAC/1 minute

MATERIAL

△BASE : high temp thermoplastic

Color : Black

△CONTACT : Stainless steel with silver plating.

△TERMINAL : brass with silver plating.

△STEM : high temp thermoplastic

Color : White

△COVER : Stainless steel with silver plating.

△CAP : high temp thermoplastic

△CAP LOCK : high temp thermoplastic

SOLDERING PROCESS

△CLEANING:

1. Only Tape sealed types apply to wash process.
2. Do not remove the tape before wash process.
3. After soldering process, do not continue the wash process immediately. Please wait for at least 3 minutes.
4. Apply alcoholic solvents as cleaning agent do not use other solvents or water.
5. Ultrasonic cleaning is not recommended.
6. The cleaning process per stage is max. 1 minute and the whole cleaning time are not to exceed 3 minutes.
7. Do not impose any external force on switch while washing.

△ Any flux enters the switch may fail the conductivity.

△Reflow Temperature Profile: (reference)

PACKING

| Part Number | Number Per Tube | Number Per Tray |
|-------------|-----------------|-----------------|
| ML6-H0 | - | 140 |
| ML6-H□ | - | 100 |