

CAD FILE:

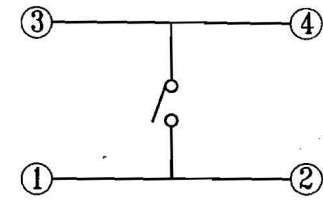

SCHEMATIC

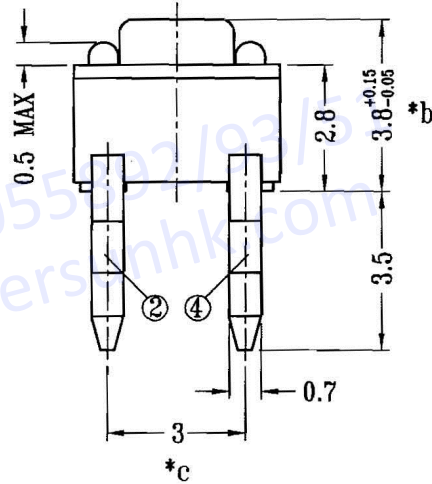
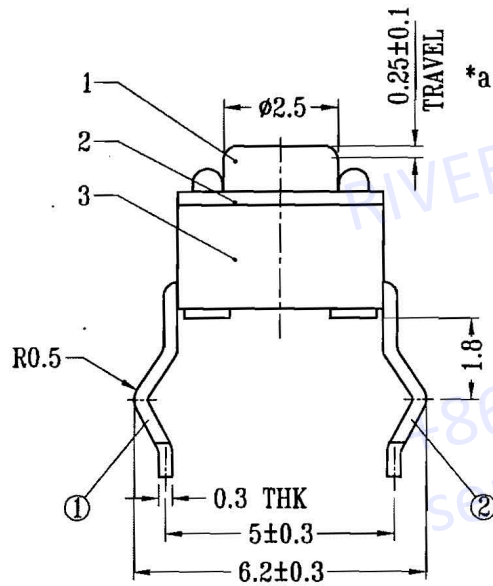
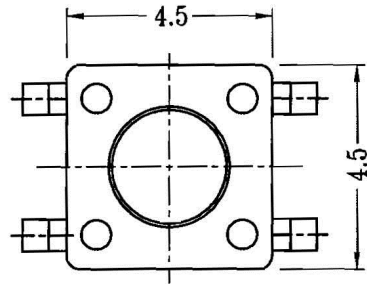
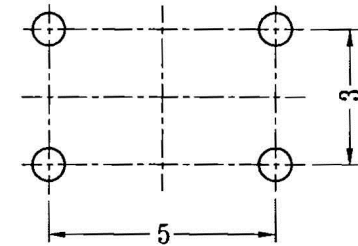

**P.C.B LAYOUT
BOTTOM VIEW**

注：“*”表示关键尺寸(3个)

NO.	PARTS	MATERIALS	Q'TY	FINISH	TOLERANCE UNLESS SPECIFIED				
8									
7									
6					WITHIN 1.5mm : ±0.1mm	A	26-Nov-2008	初版	
5					OVER 1.5mm : ±0.2mm	ISSUE	DATE	DESCRIPTIONS OF REVISION	
4	CONTACT	SUS	1	Ag CLAD	TITLE : TACT SWITCH			UNIT : mm	DRWG NO.:
3	CASE	NYLON+F.G , PA46/BRASS STRIP	1	BLACK/Ag PLATED OVER Ni PLATED	MODEL: TC-0010			SCALE: 6:1	DWN.
2	COVER	PET/ZINE PLATE	1	CLEAR/Ni PLATED					CHK'D
1	KNOB	NYLON+F.G/PA9T	1	BLACK					APPD.