

TD-12ED

CIRCUIT DIAGRAM

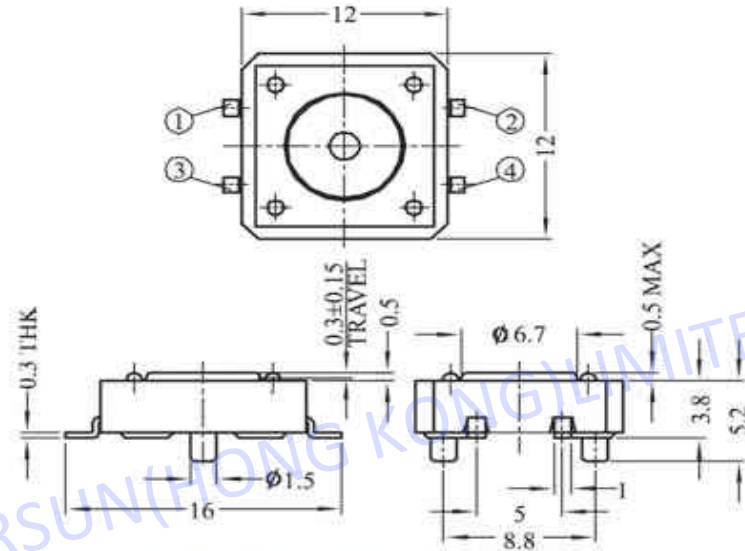
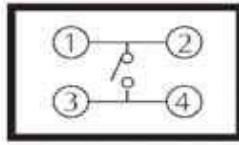

RATING: DC 12V 50mA

轻触开关主要技术特性

The Main Technical Characteristic Tact Switch

额定负荷	DC 12V 50mA	操作温度	-16℃ to 60℃
Rated Load		Operating Temperature	
接触电阻	< 100 mΩ	寿命	100,000 次
contact Resistance		Life Test	
绝缘电阻	> 100 MΩ	作用力	X 160gf ± 50gf Z 250gf ± 100gf
Insulation Resistance		Operating Force	
耐电压	250V 0.5mA/min		