

TD-12EF

CIRCUIT DIAGRAM

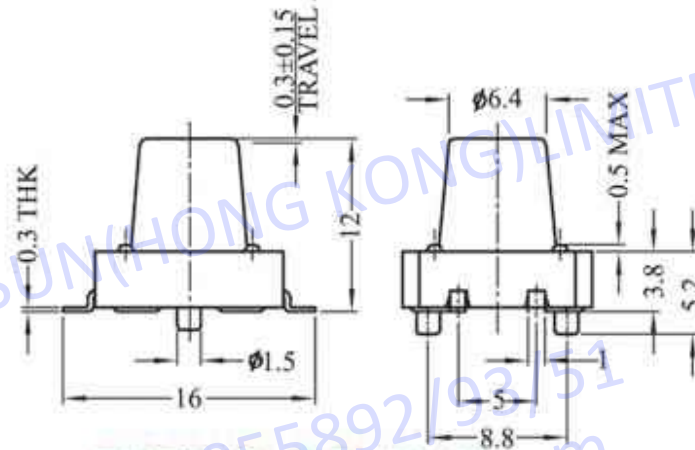
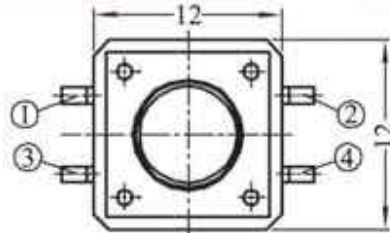
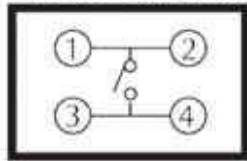

RATING: DC 12V 50mA

轻触开关系列主要技术先特性

Tact Switch Series Main Technical Characteristics

额定负荷	DC 12V 50mA	耐电压	250V 0.5mA/min
Rated Load		Dielectric Strength	
接触电阻	< 100 mΩ	操作温度	-16°C to 60°C
contact Resistance		Operating Temperature	
绝缘电阻	> 100 MΩ	寿命	100,000 次
Insulation Resistance		Life Test	